

# Buckle Security Covers

ART NOS. FS029C

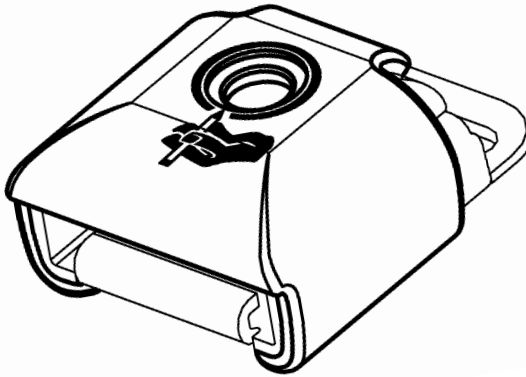

**⚠ WARNING!** This product is intended to prevent unintentional release of a belt by the user. Improper use of this product could result in a user being trapped in the wheelchair in an emergency. A caregiver with a release tool should be present at all times during use of this product. Avoid the use of this product as a restraint unless a physician has weighed the risks and determined that it will increase the user's safety.

**WARRANTY:** This product carries a limited lifetime warranty against defects in workmanship and materials arising under normal use by the original consumer. Contact your supplier or Bodypoint for warranty claims.

For more information on Bodypoint products, and a list of distributors outside the USA, go to [www.bodypoint.com](http://www.bodypoint.com)



MDSS GmbH  
Schiffgraben 41  
D-30175 Hannover  
Germany



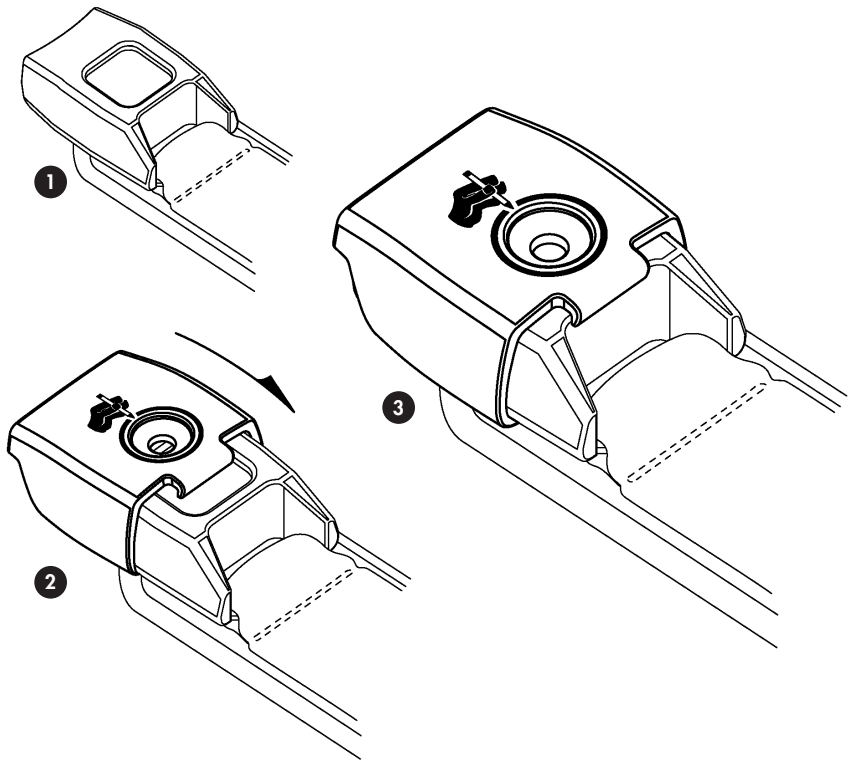

Ø 1/4" (6mm) max.

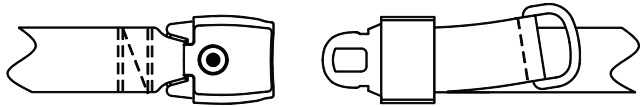
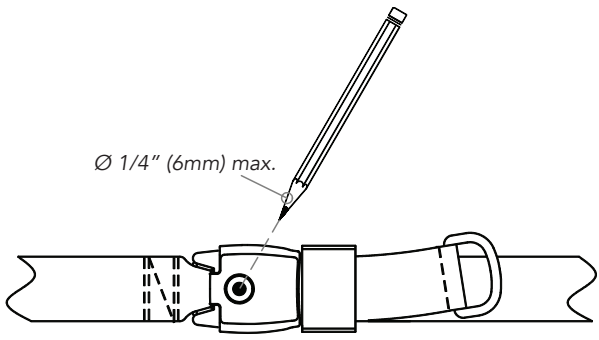

# Funda De Seguridad Para La Hebilla

ART NOS. FS029C

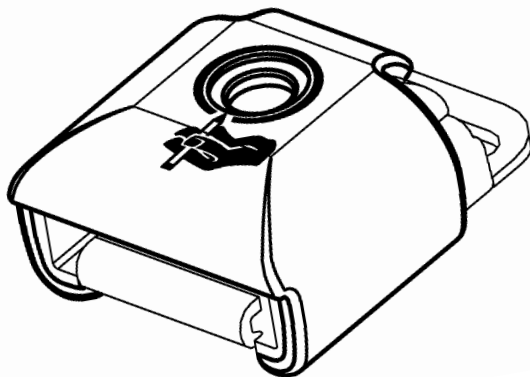

**⚠ ¡ADVERTENCIA!** Este producto está diseñado para impedir que el usuario suelte la correa de forma no intencional. El uso inapropiado de este producto podría dar como resultado que el usuario quedara atrapado en la silla de ruedas durante una emergencia. Cuando se usa este producto, debería estar presente siempre un asistente con una herramienta para liberación de la correa. Evite usar este producto como elemento de restricción, a menos que un doctor haya estimado los riesgos y haya determinado que va a aumentar la seguridad del usuario.

**GARANTÍA:** Este producto tiene una garantía limitada para toda la vida contra defectos de mano de obra y materiales derivados de un uso normal por el paciente original. Póngase en contacto con su suministrador o con Bodypoint si desea realizar reclamaciones bajo garantía.

Si desea obtener más información sobre productos de Bodypoint y una lista de distribuidores fuera de EE.UU., visite la página [www.bodypoint.com](http://www.bodypoint.com)

 **Bodypoint**®

**EC REP**

MDSS GmbH  
Schiffsgraben 41  
D-30175 Hannover  
Germany

**CE**

558 First Ave. S., Suite 300 | Seattle, WA 98104 | 206.405.4555 | 800.547.5716 | [www.bodypoint.com](http://www.bodypoint.com)

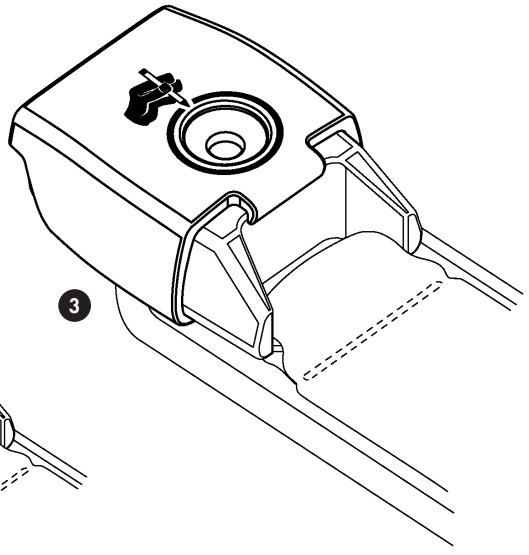
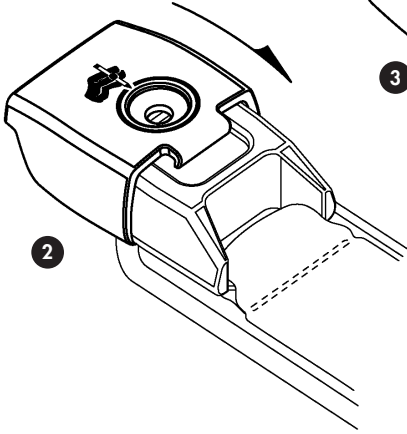
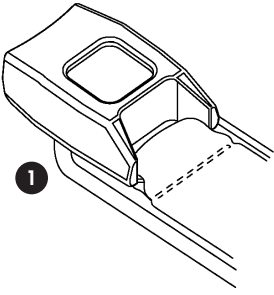

Ø 1/4" (6mm) max.

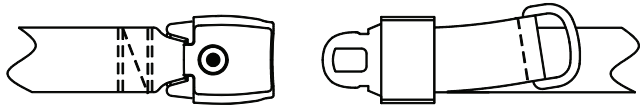
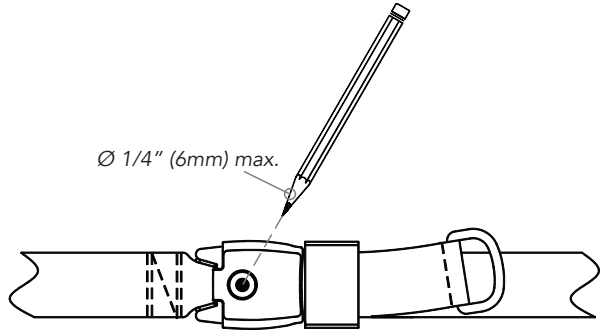

# Protege-Boucle De Securite

ART NOS. FS029C

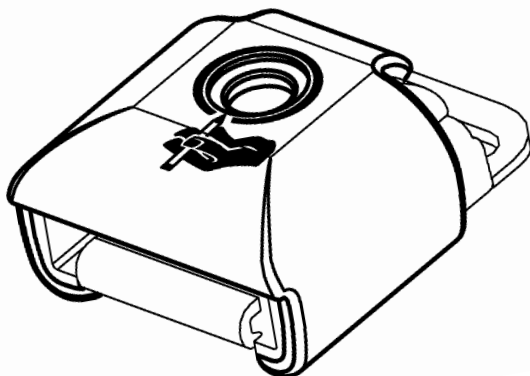

**⚠ ATTENTION !** Ce produit est conçu pour empêcher l'ouverture accidentelle d'une ceinture par l'utilisateur. Une mauvaise utilisation de ce produit risque d'immobiliser l'utilisateur dans le fauteuil roulant en cas d'urgence. Un soignant équipé d'un outil d'ouverture doit être présent en permanence lorsque ce produit est utilisé. Ne pas utiliser ce produit en tant que dispositif de retenue sans l'assentiment d'un médecin qui aura évalué les risques et conclu que cela augmenterait la sécurité de l'utilisateur.

**GARANTIE :** Ce produit est couvert par une garantie à vie limitée contre les défauts d'exécution et de matériaux survenant dans le cadre d'une utilisation normale par le consommateur d'origine. Contacter le fournisseur ou Bodypoint pour faire valoir la garantie.

Pour plus d'informations sur les produits Bodypoint, ou consulter la liste des distributeurs en dehors des États-Unis, rendez-vous sur [www.bodypoint.com](http://www.bodypoint.com)

 **Bodypoint**®

**EC REP**

MDSS GmbH  
Schiffgraben 41  
D-30175 Hannover  
Germany

**CE**

558 First Ave. S., Suite 300 | Seattle, WA 98104 | 206.405.4555 | 800.547.5716 | [www.bodypoint.com](http://www.bodypoint.com)

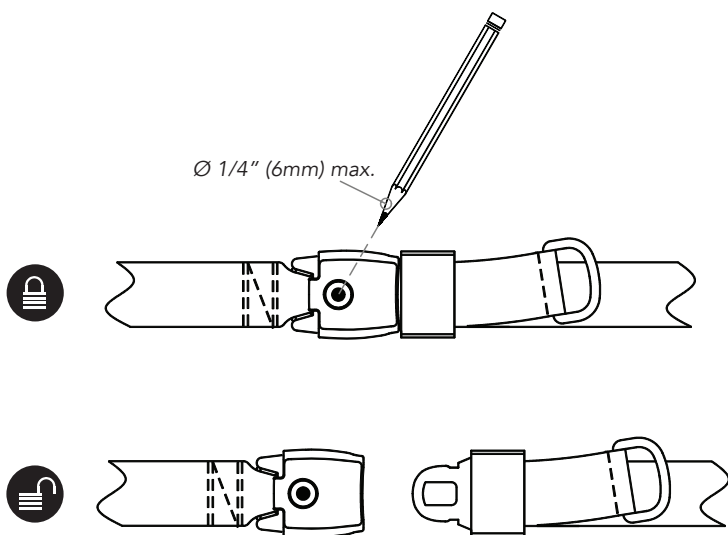
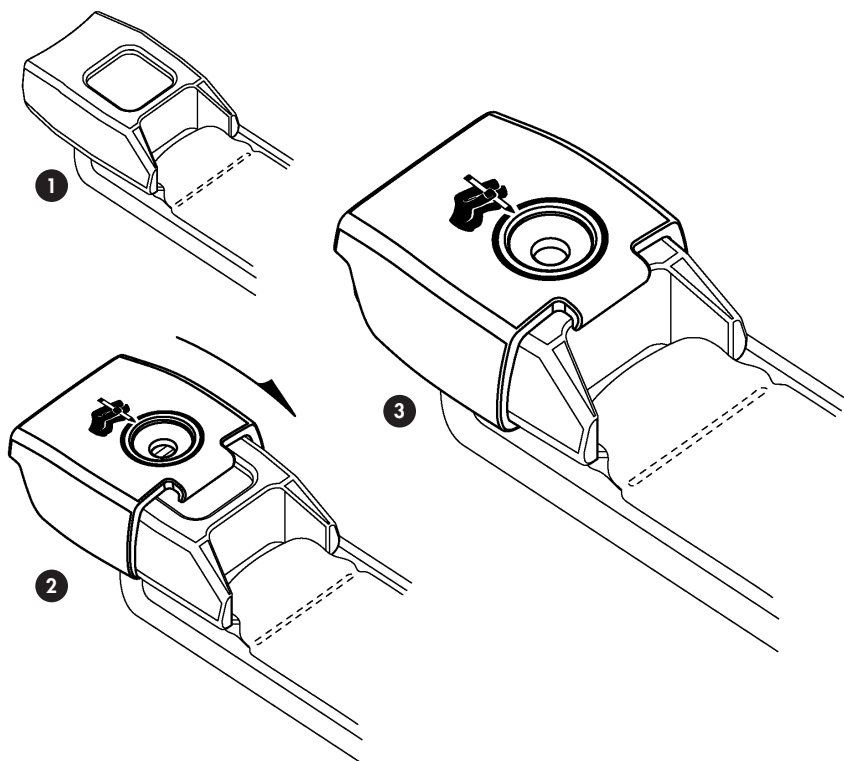

# Säkerhetslock

ART NOS. FS029C

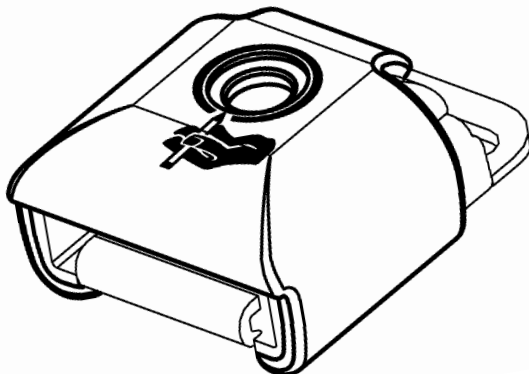

**⚠ VARNING!** Denna produkt är avsedd att förhindra att ett bälte låses upp oavsiktligt av användaren. Felaktig användning av denna produkt kan leda till att användaren fastnar i rullstolen i ett nödläge. En vårdare med ett upplåsningsverktyg skall alltid vara närvarande vid användning av denna produkt. Undvik att använda denna produkt för fastspänning om inte en läkare har bedömt riskerna och konstaterat att detta ökar användarens säkerhet.

**GARANTI:** Produkten har en livstidsgaranti mot brister i tillverkning och material som kan uppstå vid normal användning av den ursprungliga användaren. Kontakta din leverantör eller Bodypoint i garantirenden.

För mer information om Bodypoints produkter kontakta leverantören. Information finns även på [www.bodypoint.com](http://www.bodypoint.com), som som också innehåller en lista med distributörer utanför USA.

 **Bodypoint**<sup>®</sup>

**EC REP**

MDSS GmbH  
Schiffgraben 41  
D-30175 Hannover  
Germany

**CE**

558 First Ave. S., Suite 300 | Seattle, WA 98104 | 206.405.4555 | 800.547.5716 | [www.bodypoint.com](http://www.bodypoint.com)

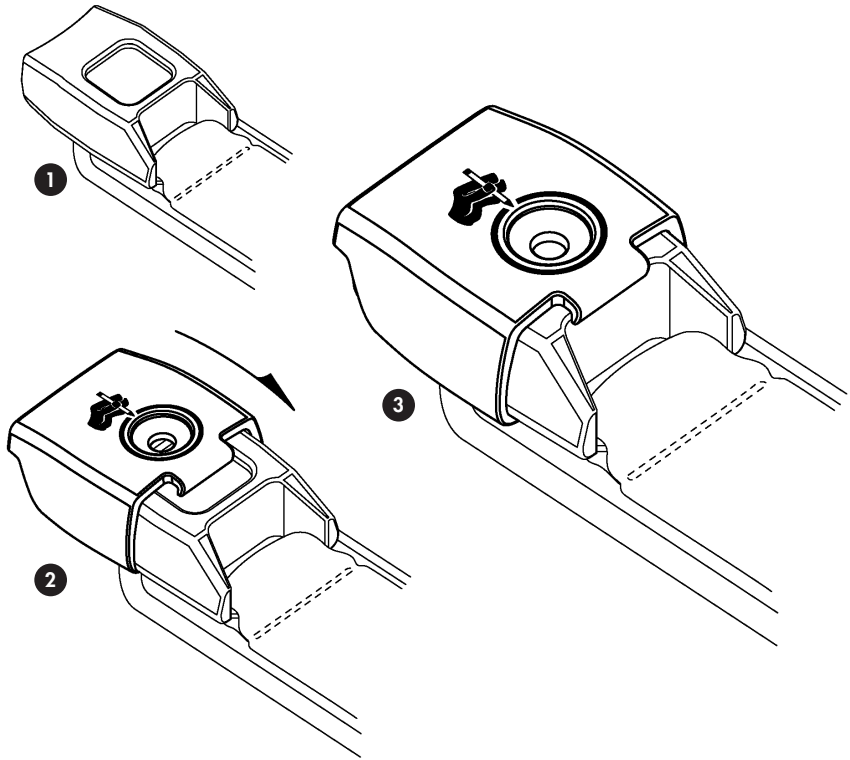

Ø 1/4" (6mm) max.

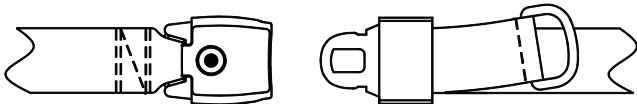
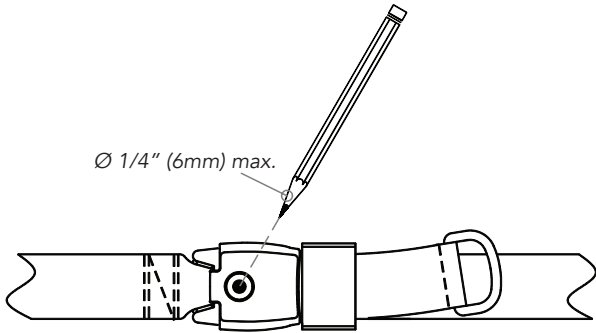



# Soljen Turvakotelo

ART NOS. FS029C

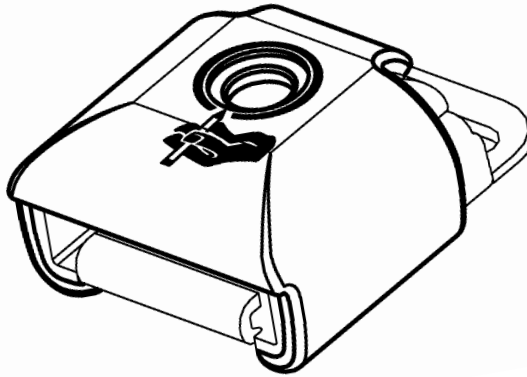

**⚠ VAROITUS!** Tämä tuote on tarkoitettu estämään käyttäjää avaamasta vyötä vahingossa. Mikäli tuotetta käytetään väärin, voi käyttäjä hätätapauksessa jäädä tuoliin vangiksi. Tuotetta käytettäessä tulisi paikalla aina olla hoitaja, jolla on tarvittavat välineet vyön avaamiseksi. Vältä tuotteen käyttöä potilaan sitomiseen, ellei lääkäri ole harkinnut vaaratekijöitä ja todennut, että käyttö lisää käyttäjän turvallisuutta.

**TAKUU:** Tällä tuotteella on rajoitettu elinikäinen takuu, joka koskee valmistus- ja materiaalivirheitä normaalissa, alkuperäisen ostajan käytössä. Käänny jälleenmyyjäsi tai Bodypoint:in puoleen takuuvaatimusasioissa.

Halutessasi lisätietoja tästä ja muista Bodypoint-tuotteista sekä Yhdysvaltojen ulkopuolisista jälleenmyyjistä, vieraile sivulla [www.bodypoint.com](http://www.bodypoint.com).

**BP** Bodypoint®

**EC REP**

MDSS GmbH  
Schiffgraben 41  
D-30175 Hannover  
Germany

**CE**

558 First Ave. S., Suite 300 | Seattle, WA 98104 | 206.405.4555 | 800.547.5716 | [www.bodypoint.com](http://www.bodypoint.com)

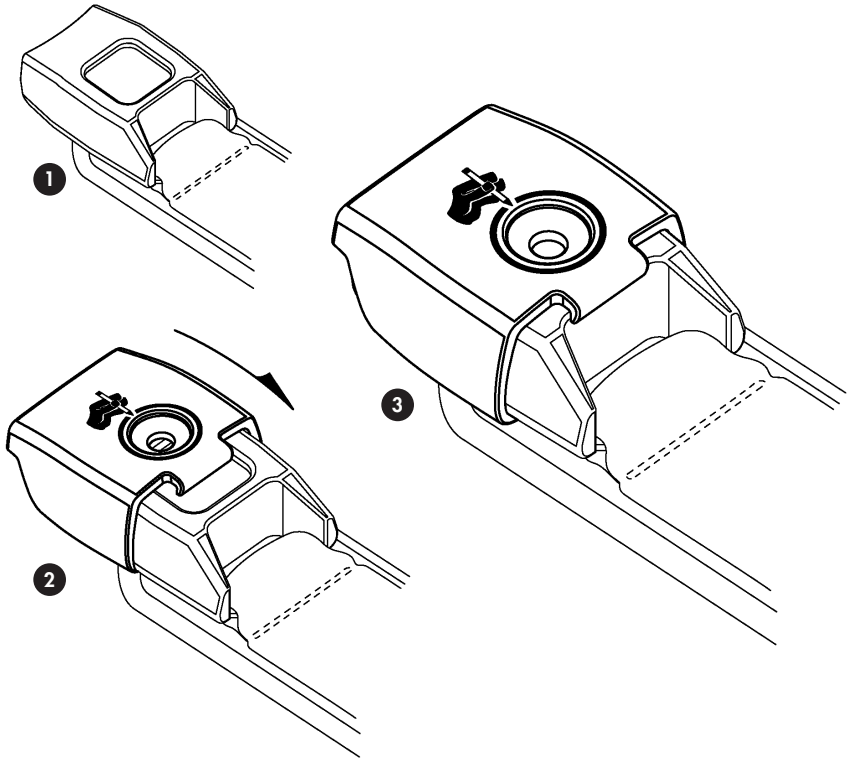

Ø 1/4" (6mm) max.

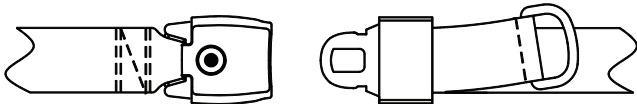
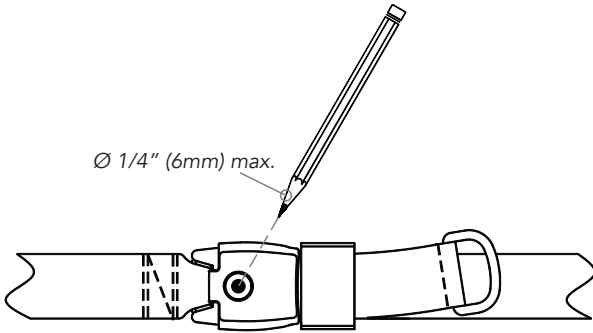

# Schnallen- Sicherheitsabdeckung

ART NOS. FS029C

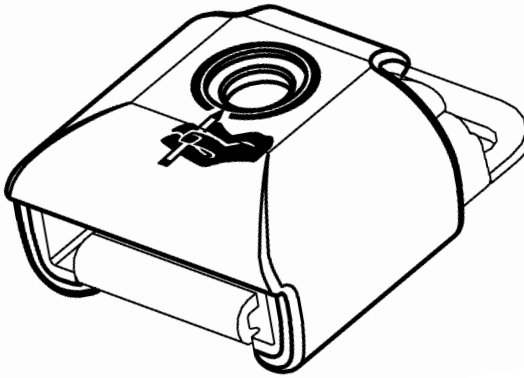

**⚠ WARNHINWEIS!** Dieses Produkt ist dafür vorgesehen, unabsichtliches Öffnen des Gurtes durch den Patienten zu verhindern. Wenn das Produkt nicht sachgemäß verwendet wird, kann der Patient in einem Notfall möglicherweise nicht aus dem Rollstuhl befreit werden. Beim Einsatz des Produkts sollte stets eine Pflegeperson mit einem Werkzeug zum Öffnen des Gurtes anwesend sein. Verwenden Sie das Produkt nicht zur Fixierung, es sei denn, ein Arzt hat nach Abwägung der Risiken festgestellt, dass dies die Sicherheit des Patienten erhöht.

**GARANTIE:** Für dieses Produkt besteht eine eingeschränkte Gewährleistung auf Fehler in Material und Verarbeitung, die bei bestimmungsgemäßem Gebrauch durch den ursprünglichen Kunden entstehen. Wenden Sie sich im Garantiefall an den Lieferant oder Bodypoint.

Weitere Informationen über Bodypoint Produkte und eine Liste der Vertreter außerhalb der USA befinden sich auf der Webseite [www.bodypoint.com](http://www.bodypoint.com).

**Bodypoint**®

**EC REP**

MDSS GmbH  
Schiffgraben 41  
D-30175 Hannover  
Germany

**CE**

558 First Ave. S., Suite 300 | Seattle, WA 98104 | 206.405.4555 | 800.547.5716 | [www.bodypoint.com](http://www.bodypoint.com)

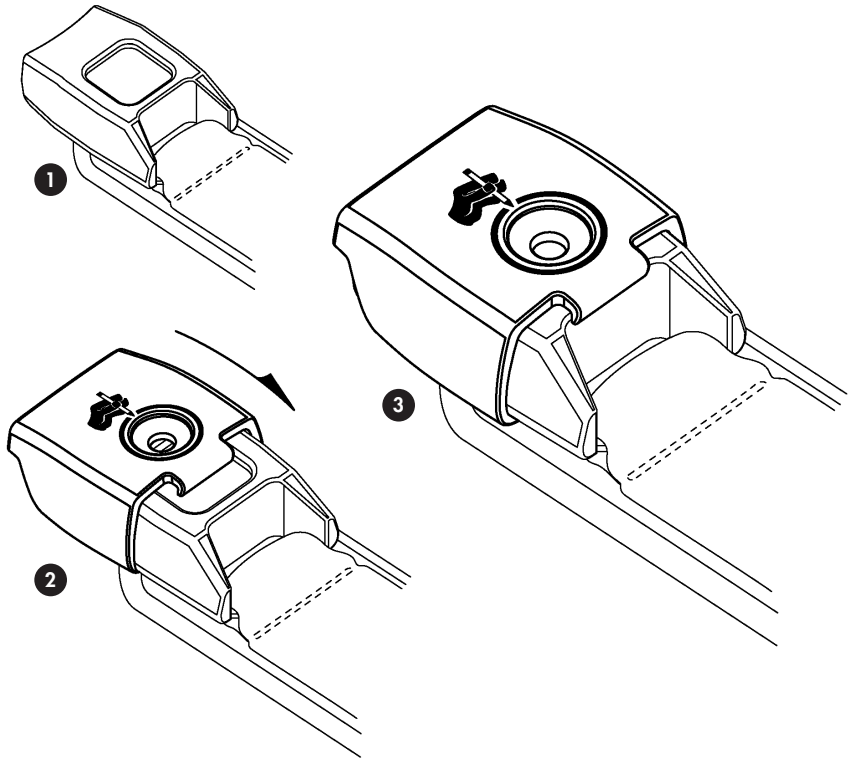

Ø 1/4" (6mm) max.

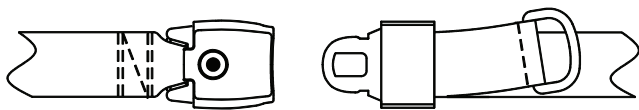
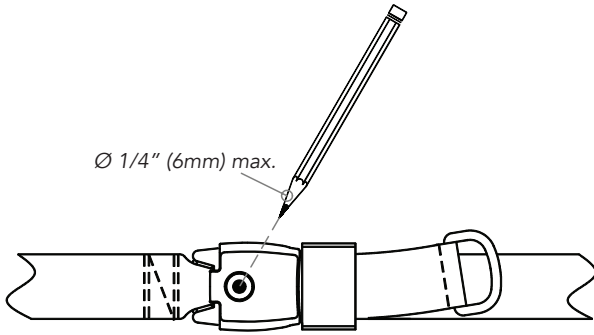

# Coprifibbia Di Sicurezza

ART NOS. FS029C

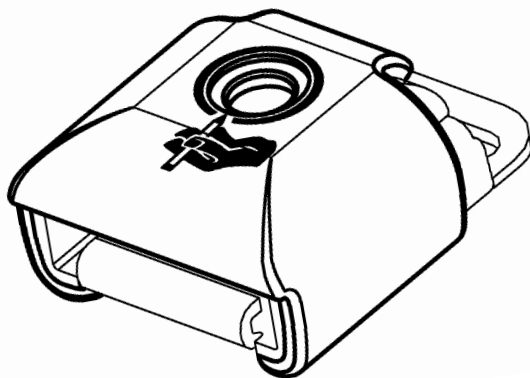

**⚠ AVVERTENZA!** Questo prodotto è stato studiato per prevenire lo sgancio involontario di una cintura da parte dell'utilizzatore. Un uso improprio del prodotto potrebbe comportare l'intrappolamento dell'utilizzatore sulla sedia a rotelle in una situazione di emergenza. Un assistente munito di uno strumento per lo sgancio deve essere sempre presente durante l'utilizzo del prodotto. Evitare di utilizzare questo prodotto come dispositivo di ritenuta a meno che un medico abbia valutato i rischi e determinato che ciò può aumentare la sicurezza dell'utilizzatore.

**GARANZIA:** Il prodotto è coperto da una garanzia a vita limitata contro eventuali difetti dei materiali e di fabbricazione che sorgano durante il normale impiego da parte del consumatore originale. Per le richieste in garanzia, contattare il proprio fornitore o Bodypoint, Inc.

Per maggiori informazioni su questo o su altri prodotti BodyPoint, e per un elenco di distributori al di fuori degli USA, visitare il sito [www.bodypoint.com](http://www.bodypoint.com).

 **Bodypoint**®

**EC REP**

MDSS GmbH  
Schiffgraben 41  
D-30175 Hannover  
Germany

**CE**

558 First Ave. S., Suite 300 | Seattle, WA 98104 | 206.405.4555 | 800.547.5716 | [www.bodypoint.com](http://www.bodypoint.com)

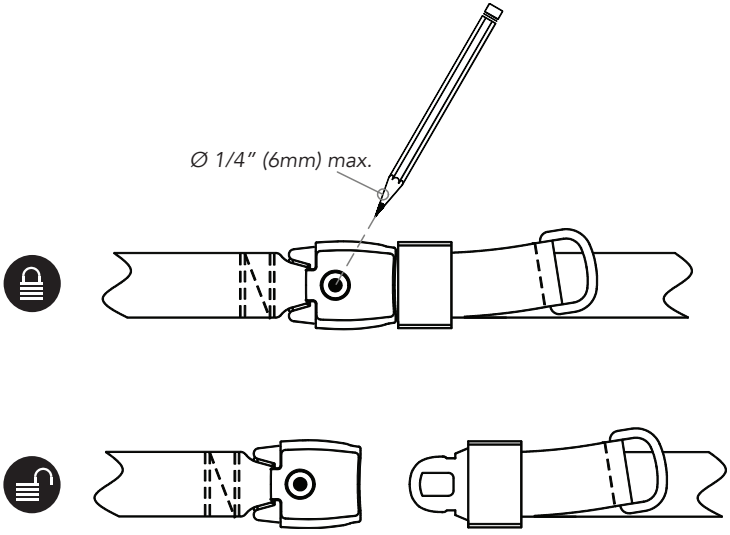
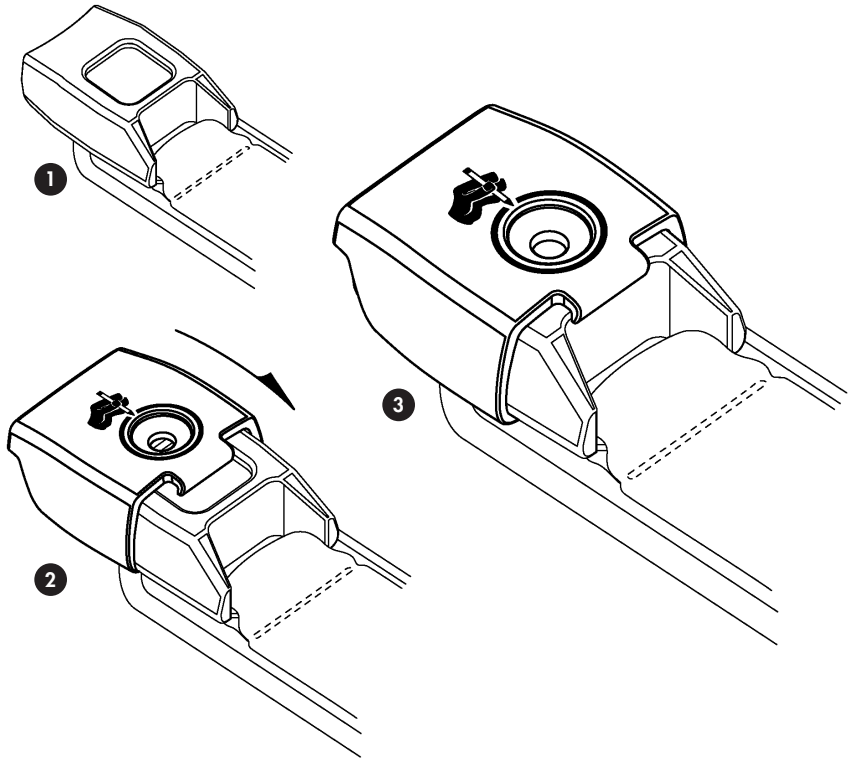

# Tampa de Segurança da Fivela

ART NOS. FS029C

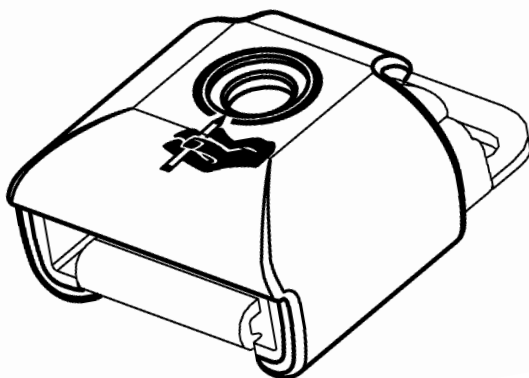

**⚠ AVISO!** Este produto destina-se a evitar a libertação acidental de um cinto pelo utilizador. A utilização indevida deste produto pode causar que o utilizador fique preso na cadeira de rodas em caso de emergência. Durante a utilização deste produto, tem de estar sempre presente um acompanhante com uma ferramenta de libertação. Evite a utilização deste produto como imobilização, excepto se o médico tiver avaliado os riscos e determinado que vai aumentar a segurança do utilizador.

**GARANTIA:** Este produto engloba uma garantia vitalícia limitada contra defeitos de fabrico e materiais sob utilização normal pelo comprador original. Contacte o fornecedor ou a Bodypoint, Inc. para reclamações da garantia.

Para mais informações sobre produtos Bodypoint e uma lista de distribuidores fora dos EUA, consultar [www.bodypoint.com](http://www.bodypoint.com).

 Bodypoint®

 EC REP

MDSS GmbH  
Schiffgraben 41  
D-30175 Hannover  
Germany

 CE

558 First Ave. S., Suite 300 | Seattle, WA 98104 | 206.405.4555 | 800.547.5716 | [www.bodypoint.com](http://www.bodypoint.com)

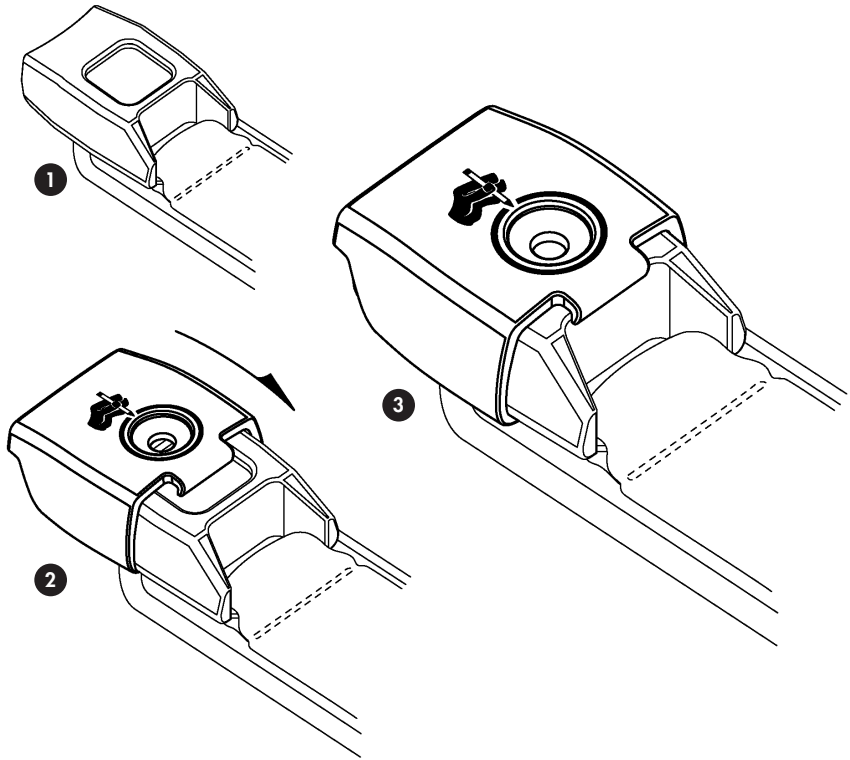

Ø 1/4" (6mm) max.

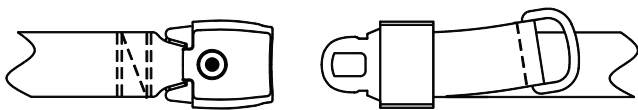
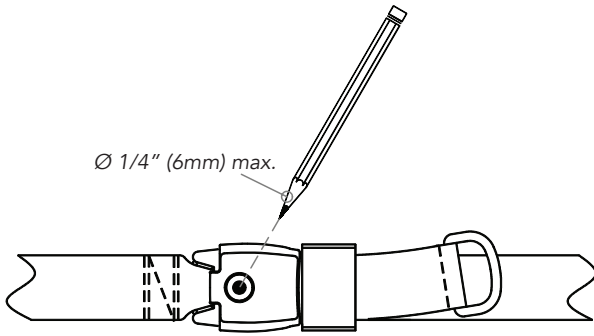



# Sikkerhetsdeksel Spenne

ART NOS. FS029C

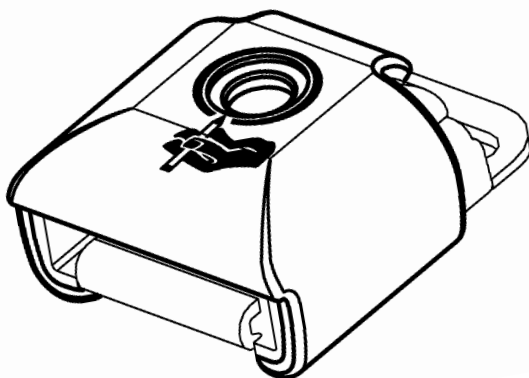

**⚠ ADVARSEL!** Dette produktet er beregnet på å hindre at selen løsnes uten at brukeren hadde tenkt å gjøre det. Feilbruk av dette produktet kan føre til at brukeren blir sittende fast i rullestolen i en nødssituasjon. En omsorgsytter med et utløsningsverktøy skal til alle tider være tilstede. Unngå å bruke dette produktet for å sikre brukeren unntatt hvis lege etter å ha vurdert risikoen avgjør at bruken øker brukerens sikkerhet.

**GARANTI:** Dette produktet er dekket av en begrenset livstidsgaranti mot feil i utførelse og materialer som måtte oppstå ved vanlig bruk av den opprinnelige forbruker. Ta kontakt med leverandøren eller Bodypoint, Inc. hvis du har krav som du mener skal dekkes under garantien.

Se [www.bodypoint.com](http://www.bodypoint.com) for ytterligere informasjon om andre produkter fra Bodypoint, samt en oversikt over forhandlere utenfor USA.

 Bodypoint®

**EC REP**

MDSS GmbH  
Schiffgraben 41  
D-30175 Hannover  
Germany

**CE**

558 First Ave. S., Suite 300 | Seattle, WA 98104 | 206.405.4555 | 800.547.5716 | [www.bodypoint.com](http://www.bodypoint.com)

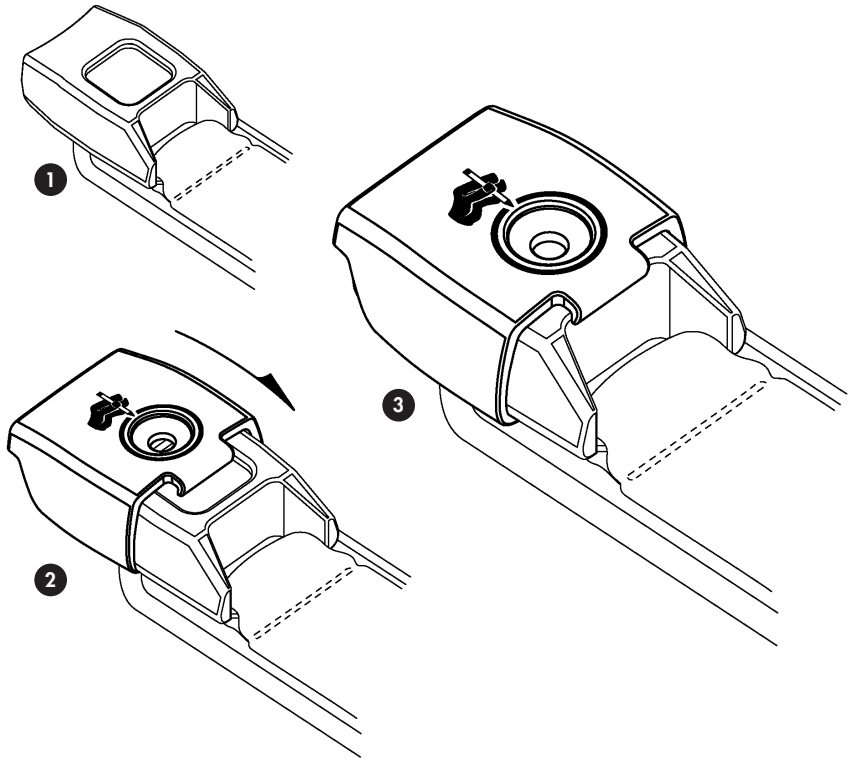

Ø 1/4" (6mm) max.

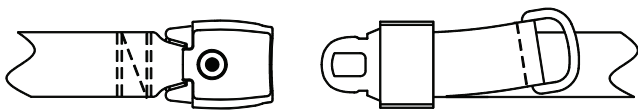
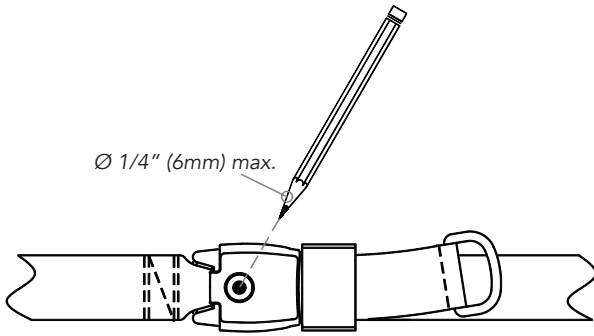

# Sikkerhedsdæksel Til Spænde

ART NOS. FS029C

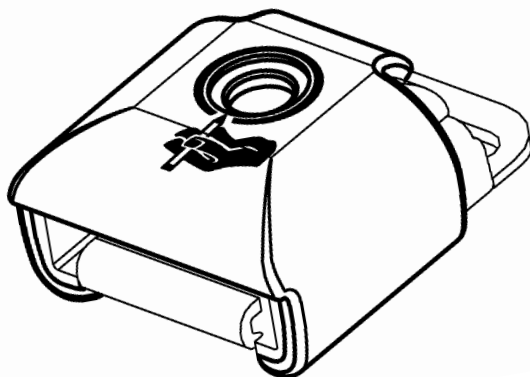

**⚠ ADVARSEL!** Dette produkt skal forhindre brugeren i at komme til at løsne remmen utilsigtet. Bliver produktet anvendt forkert, kan det medføre, at brugeren fastlåses i kørestolen i en nødsituation. Der skal altid være en plejer med et frigøringsværktøj til stede, mens dette produkt er i brug. Dette produkt må ikke anvendes som en fæstholdelsesmekanisme, medmindre en læge har afvejet diverse risici og afgjort, at brugerens sikkerhed dermed øges.

**GARANTI:** Med dette produkt følger en begrænset livstidsgaranti mod defekter på fabrikation og materialer, der opstår under normal brug af den oprindelige køber. Kontakt Deres Bodypoint-forhandler ved garantisager.

Der kan indhentes yderligere oplysninger om Bodypoint-produkter, samt en liste over distributører udenfor USA, på [www.bodypoint.com](http://www.bodypoint.com).



MDSS GmbH  
Schiffgraben 41  
D-30175 Hannover  
Germany



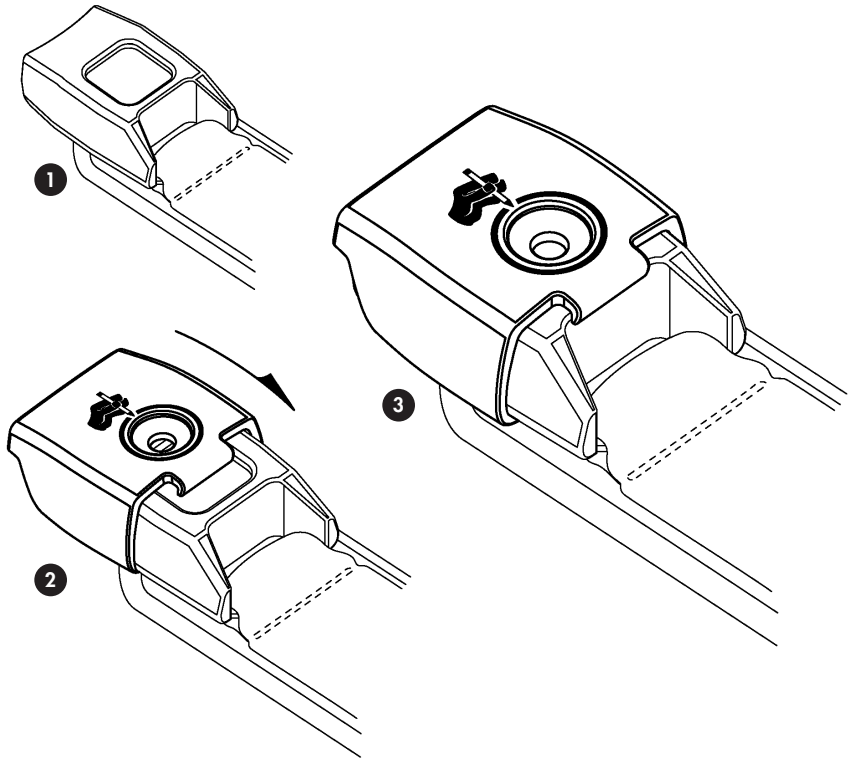

Ø 1/4" (6mm) max.

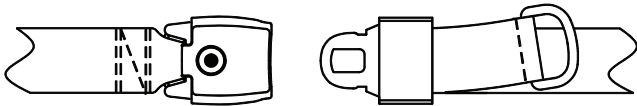
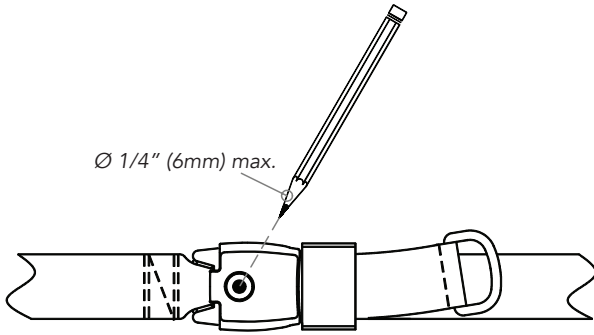

# Overtrek Voor Veiligheidsriem

ART NOS. FS029C

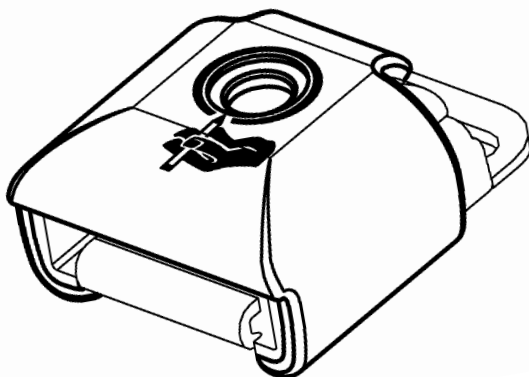

**⚠ WAARSCHUWING!** Dit product is bedoeld om te voorkomen dat een riem per ongeluk losraakt. Onjuist gebruik van dit product kan ertoe leiden dat de gebruiker in geval van nood in de rolstoel beklemd raakt. Wanneer dit product wordt gebruikt, moet altijd een zorgverlener met een bevrijdingsgereedschap in de buurt zijn. Gebruik dit product niet als vrijheidsbeperkend middel, tenzij een arts de risico's goed heeft overwogen en heeft bepaald dat het de veiligheid van de gebruiker ten goede komt.

**GARANTIE:** Voor dit product geldt een beperkte levenslange garantie tegen materiaal- en fabrieksfouten die optreden bij normaal gebruik bij de originele gebruiker. Neem contact op met uw leverancier of met Bodypoint voor garantieclaims.

Kijk voor meer informatie over Bodypointproducten en voor een overzicht van verkooppunten buiten de VS op [www.bodypoint.com](http://www.bodypoint.com).

 **Bodypoint**<sup>®</sup>

**EC REP**

MDSS GmbH  
Schiffgraben 41  
D-30175 Hannover  
Germany

**CE**

558 First Ave. S., Suite 300 | Seattle, WA 98104 | 206.405.4555 | 800.547.5716 | [www.bodypoint.com](http://www.bodypoint.com)

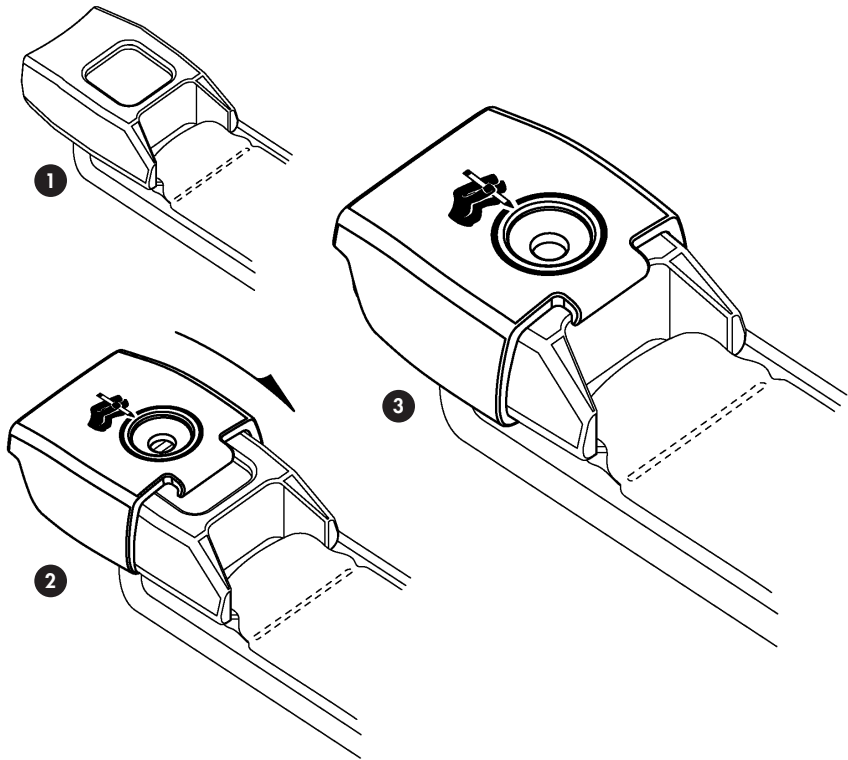

Ø 1/4" (6mm) max.

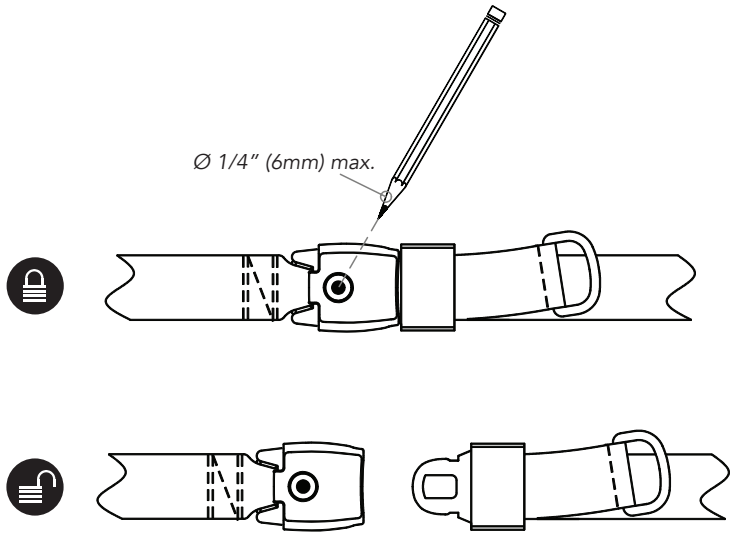

# Bezpečnostní Kryt Přezky

ART NOS. FS029C

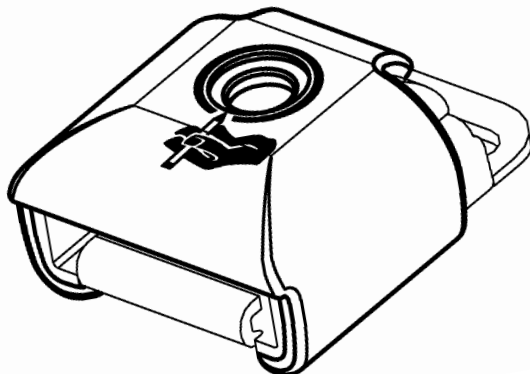

**⚠ VAROVÁNÍ!** Tento výrobek je určen k předcházení neúmyslného rozeptnutí pásu uživatelem. Nesprávné použití tohoto výrobku může vést k tomu, že bude uživatel v nouzové situaci uvězněn v kolečkovém křesle. Při používání tohoto produktu musí být vždy přítomen pečovatel s uvolňovacím nástrojem. Tento produkt nepoužívejte jako omezovací prostředek, ledaže lékař zvážil veškerá rizika a určil, že to zvýší bezpečnost uživatele.

**ZÁRUKA:** Na tento výrobek se vztahuje omezená celoživotní záruka na vady zpracování a materiálu, které se vyskytnou při běžném používání původním spotřebitelem. V případě reklamace se obraťte na dodavatele nebo společnost Bodypoint.

Další informace o výrobcích společnosti Bodypoint a seznam distributorů mimo USA najdete na stránkách [www.bodypoint.com](http://www.bodypoint.com).

 **Bodypoint®**

**EC REP**

MDSS GmbH  
Schiffgraben 41  
D-30175 Hannover  
Germany

**CE**

558 First Ave. S., Suite 300 | Seattle, WA 98104 | 206.405.4555 | 800.547.5716 | [www.bodypoint.com](http://www.bodypoint.com)

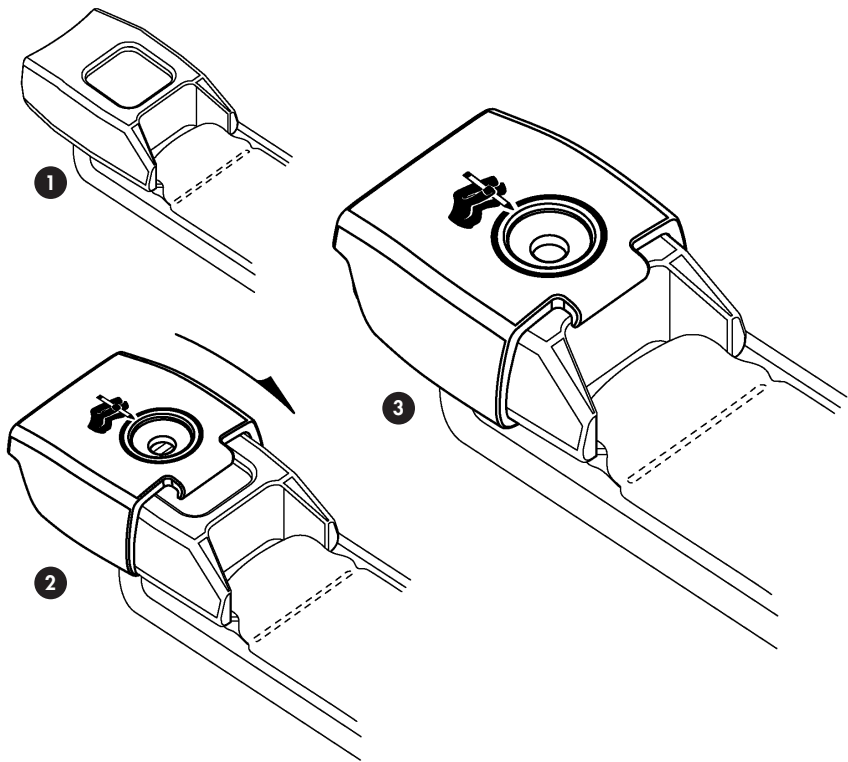

Ø 1/4" (6mm) max.

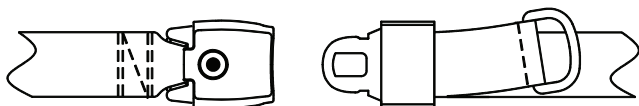
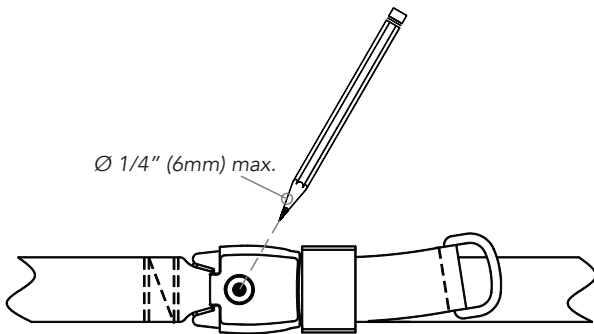



# Varnostni Pokrov za Zaponko

ART NOS. FS029C

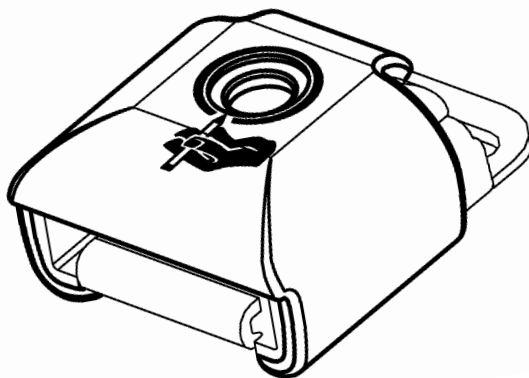

**⚠ OPOZORILO!** Ta izdelek je namenjen preprečevanju nenamerne- ga odpetja pasu s strani uporabnika. Zaradi neustrezne uporabe tega izdelka lahko uporabnik ostane ujet v invalid- skem vozičku v primeru nevarnosti. Med uporabo tega izdelka mora biti vedno prisoten negovalec z orodjem za odpetje. Izogibajte se uporabi tega izdelka v namene omejevanja, razen če je zdravnik pretehtal tveganja in določil, da uporaba v takšen namen poveča varnost uporabnika.

**GARANCIJA:** Ta izdelek ima omejeno doživljenjsko garancijo na napake pri izdelavi in materiale, ki temelji na običa- jni uporabi s strani prvotnega uporab- nika. V primeru garancijskih zahtevkov se obrnite na svojega dobavitelja ali podjetje Bodypoint.

Več informacij v Bodypoint izdelkih in seznam dobaviteljev izven ZDA najdete na spletni strani [www.bodypoint.com](http://www.bodypoint.com).

 **Bodypoint**®

**EC REP**

MDSS GmbH  
Schiffgraben 41  
D-30175 Hannover  
Germany

**CE**

558 First Ave. S., Suite 300 | Seattle, WA 98104 | 206.405.4555 | 800.547.5716 | [www.bodypoint.com](http://www.bodypoint.com)

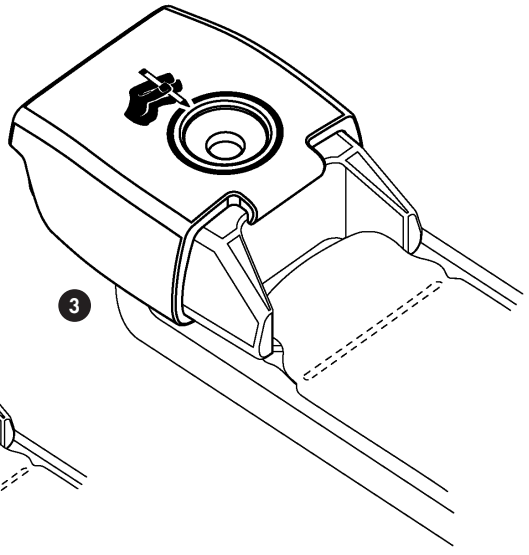
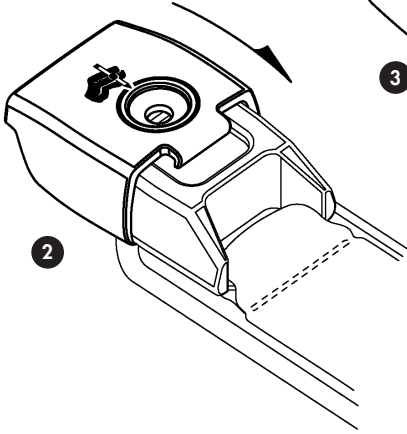
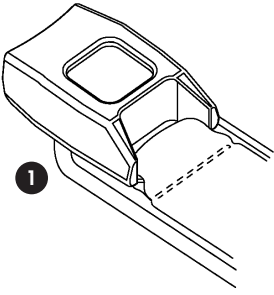

Ø 1/4" (6mm) max.

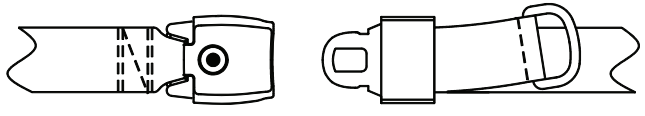
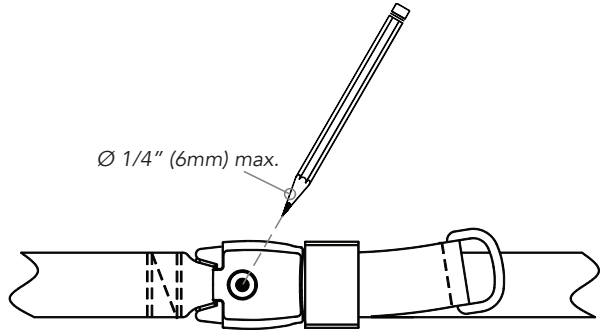

# バックル安全カバー

ART NOS. FS029C

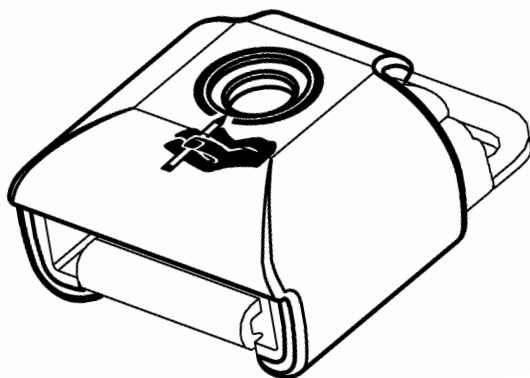

⚠ 警告! 本製品は使用者による不意のベルト解放の予防を意図しています。本製品の不適正使用により、緊急時に使用者が車椅子に捕らわれる可能性があります。本製品の使用中は常に開放工具を持った介護人が付き添わなければなりません。医師が危険を熟考して使用者の安全を増すと判断しない限り、拘束具として本製品を使用することは避けてください。

保証: この製品には、オリジナルの消費者による正常な使用から生ずる材料および仕上がりにおける瑕疵に対する生涯限定保証が付いています。保証請求については、サプライヤーまたはBodypointに連絡してください。

 Bodypoint®

 EC REP

MDSS GmbH  
Schiffsgraben 41  
D-30175 Hannover  
Germany

 CE

558 First Ave. S., Suite 300 | Seattle, WA 98104 | 206.405.4555 | 800.547.5716 | [www.bodypoint.com](http://www.bodypoint.com)

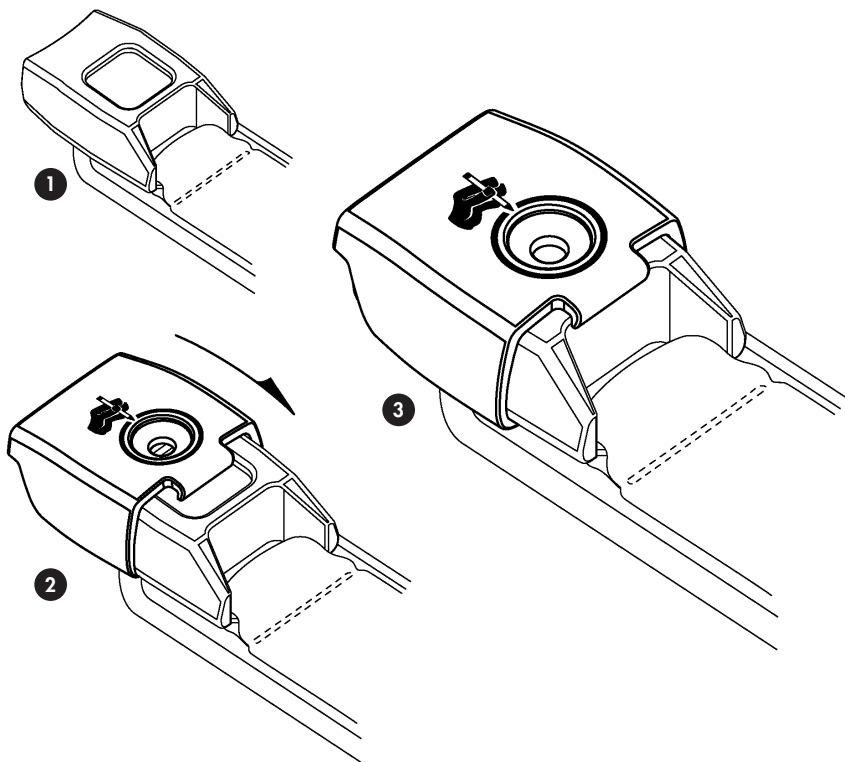

Ø 1/4" (6mm) max.

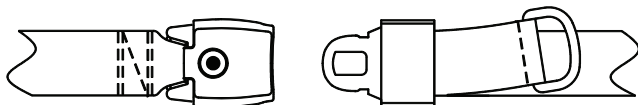
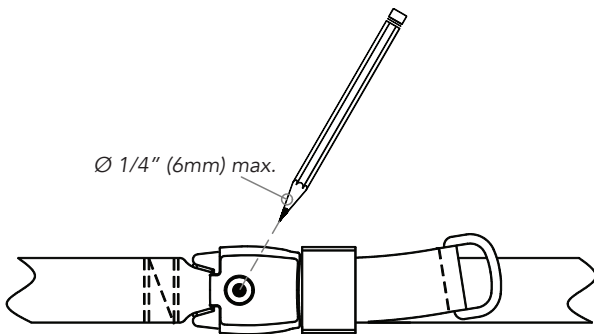

# 防松外罩

ART NOS. FS029C

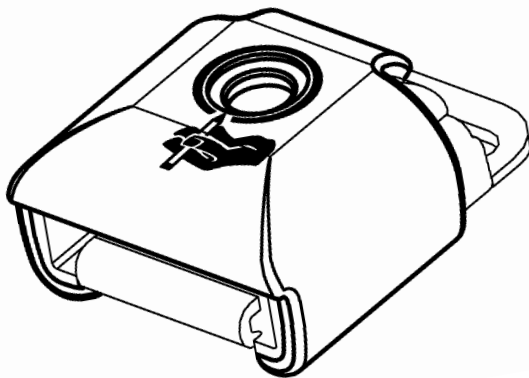

⚠ 警告! 本产品适合预防使用者意外松开腰带。本产品如果使用不当, 可能导致使用者在紧急情况下被困在轮椅上。使用本产品时, 必须始终有携带释放工具的照护者在场。除非经医生权衡风险并确定本产品能够提高使用者

的人身安全, 否则应避免使用本产品作为束缚装置。

担保: 本产品针对原始消费者正常使用下出现的工艺和材料缺陷提供有限终身保修。有关保修索赔, 请联系您的供应商或 BODY-POINT。

 Bodypoint®

 EC REP

MDSS GmbH  
Schiffgraben 41  
D-30175 Hannover  
Germany

 CE

558 First Ave. S., Suite 300 | Seattle, WA 98104 | 206.405.4555 | 800.547.5716 | [www.bodypoint.com](http://www.bodypoint.com)

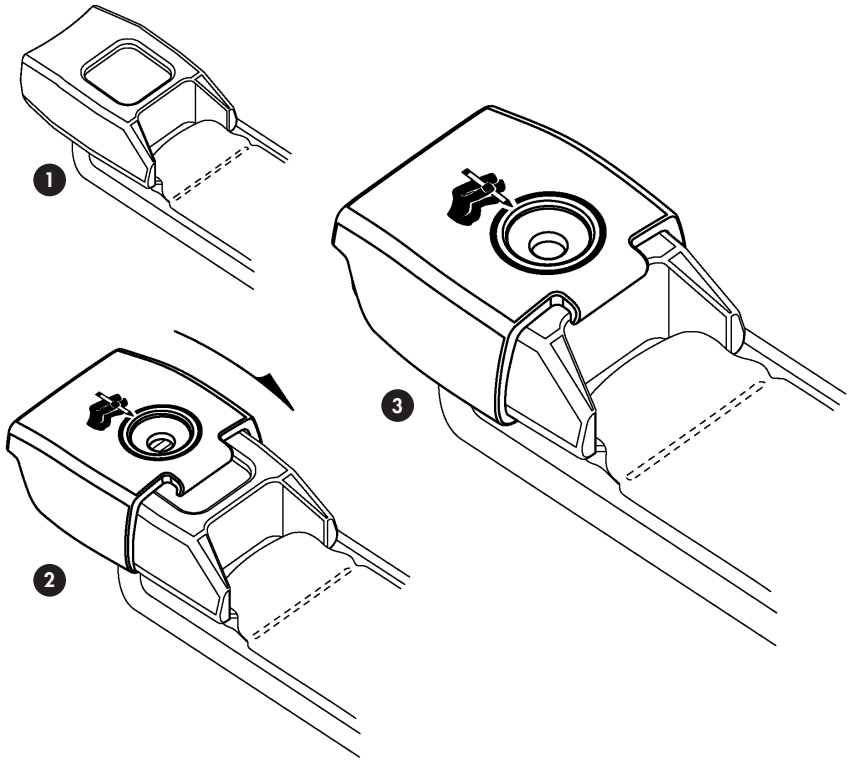

Ø 1/4" (6mm) max.

